

NON-POTABLE WATER SYSTEM STANDARDS

DIVISION 600



**BOARD OF WATER SUPPLY
CITY AND COUNTY OF HONOLULU**

January 2023

TABLE OF CONTENTS
DIVISION 600 – NON-POTABLE WATER SYSTEM STANDARDS

<u>SECTION</u>	<u>PAGE</u>
601	NON-POTABLE WATER SYSTEM DESIGN GUIDELINES
601.01	Purpose 601-1
601.02	Definitions 601-1
601.03	Uses and Requirements 601-2
601.04	References 601-2
601.05	Planning 601-3
602	NON-POTABLE WATER MASTER PLAN
602.01	General 602-1
602.02	Plans 602-1
603	NON-POTABLE WATER OFF-SITE FACILITIES
603.01	General 603-1
603.02	Distribution of Non-potable Water 603-1
603.03	Cover 603-1
603.04	Separation 603-2
603.05	Jacketing 603-2
603.06	Pipeline Materials 603-2
603.07	Pipeline and Appurtenance Identification Materials 603-4
603.08	Valves and Appurtenances 603-5
603.09	Valve Box, Castings and Cover Identification 603-6
603.10	Color-Coding Exposed Non-potable Water Appurtenances 603-7
603.11	Air Release Valves 603-7
603.12	Blowoff Lines 603-7
603.13	Corrosion Control 603-7
603.14	Meters and Meter Boxes 603-8
603.15	Miscellaneous Off-Site Recycled Water Facilities 603-8
604	NON-POTABLE WATER ON-SITE FACILITIES
604.01	General 604-1
604.02	Identification of On-Site Pipes, Fittings and Buried Pipelines ... 604-1
604.03	Separation 604-1
604.04	Cross-Connection Control 604-1
604.05	Miscellaneous On-Site Items 604-2
604.06	Signage, Decals, and Tags 604-2

<u>SECTION</u>	<u>PAGE</u>	
605	NON-POTABLE WATER FOR OTHER USES	
605.01	Construction Uses	605-1
606	RETROFITTING EXISTING FACILITIES FOR NON-POTABLE WATER USES	
606.01	Retrofitting Existing Facilities for Non-potable Water Uses	606-1
607	APPROVED MATERIALS LIST	
607.01	Pipes and Appurtenances	607-1
607.02	Valves and Appurtenances	607-1
607.03	Service Laterals, Fittings, and Appurtenances	607-1
607.04	Paints and Coatings	607-1
607.05	Miscellaneous	607-1
	Approved Material List	607-2
608	STANDARD DETAILS	
608.01	Standard Details	608-1

DIVISION 600 – NON-POTABLE WATER SYSTEM STANDARDS

SECTION 601 –NON-POTABLE WATER SYSTEM DESIGN GUIDELINES

601.01 PURPOSE.

The purpose of this section is to provide guidance and standards relating to the design and construction of Non-potable water system facilities under the jurisdiction of the Honolulu Board of Water Supply.

601.02 DEFINITIONS.

When used in section 600, the following terms, or pronouns used in place of them, shall have the meaning ascribed to them in this section, unless it is apparent from the context that a different meaning is intended:

The term Board shall mean the policy-making body of the Board of Water Supply.

The term Brackish Water (BW) shall mean water which has a salinity more than freshwater and less than salt water, with typically between 1,000 and 10,000 parts per million of total dissolved solids.

The term Contractor shall mean the party (individual, corporation, joint venture, or partnership) who has entered into the contract with the Board of Water Supply.

The term County shall mean the City and County of Honolulu.

The term Manager shall mean the Manager and Chief Engineer of the Board of Water Supply or an authorized representative.

The term Non-potable shall mean not appropriate for drinking by humans. Non-potable water shall mean recycled water, Brackish Water, and any other types of water that is not treated or defined to be potable to applicable Department of Health standards.

The term Off-Site Facilities shall mean facilities under the control of the Board of Water Supply including but not limited to water, Non-potable water pipelines, reservoirs, pumping stations, fire hydrants, manholes, valves, connections, supply interties, treatment facilities, natural treatment systems and other appurtenances and property up to the point of connection with the customer's facilities.

The term On-Site Facilities shall mean facilities under the control of the customer including but not limited to residential, commercial, and industrial building water and sewerage systems, landscape irrigation systems, and agricultural irrigation systems. For water and recycled water service, the on-site facilities shall be those downstream of the service connection, which shall normally be the downstream end of the meter tailpiece.

DIVISION 600 – NON-POTABLE WATER SYSTEM STANDARDS

The term Owner or Department shall mean the Board of Water Supply.

The term RO (Reverse Osmosis) Water shall mean recycled water that has utilized the reverse osmosis process and membrane technology as means of treatment.

The term R-1 Water (Significant reduction in viral and bacterial pathogens) shall mean recycled water that is oxidized, filtered, and disinfected as specified in Volume I, Section D, “R-1 Recycled Water” of the latest edition of the DOH *Reuse Guidelines*.

The term R-2 Water shall mean recycled water that is oxidized and disinfected as specified in Volume I, Section E, “R-2 Recycled Water” of the latest edition of the DOH *Reuse Guidelines*.

The term R-3 Water shall mean recycled water that is oxidized and meet BODs and TSS limits as specified in Volume I, Section F, “R-3 Recycled Water” of the latest edition of the DOH *Reuse Guidelines*.

The term Water System Standards shall mean the latest edition of the *Water System Standards*, and all subsequent amendments and additions approved and adopted for use by the Board of Water Supply.

601.03 USES AND REQUIREMENTS.

The uses and requirements for Non-potable water shall meet Volume II, Section D, “Suitable Uses” of the latest edition of the DOH *Reuse Guidelines*.

Brackish Water may be used in Non-potable water system facilities or in conjunction with R-1 Water. Recycled water that is lower quality than R-1 (R-2 and R-3 Water) are not considered for use.

601.04 REFERENCES.

When reference is made to known standard specifications, the most recently adopted and published edition of such specifications on the date of the notice to bidders is contemplated, unless otherwise specified.

DIVISION 600 – NON-POTABLE WATER SYSTEM STANDARDS

601.05 PLANNING

A. Non-potable Demand Guideline.

The guidelines for Non-potable water demand for a dual water system are listed in Table 601-01. The Non-potable water distribution system is not designed to provide fire flow.

Table 601-01 NON-POTABLE DEMAND GUIDELINES			
Land Use	Dual Water System Average Daily Demands		
	Total Dual Water System Demands	Potable	Non-potable
Single Family ¹	400 GPD/Unit or 2,000 GPD/Acre	400 GPD/Unit or 2,000 GPD/Acre	-
Multi-Family Low Rise	300 GPD/Unit or 3,000 GPD/Acre	210 GPD/Unit or 2,100 GPD/Acre	90 GPD/Unit or 900 GPD/Acre
Multi-Family High Rise	200 GPD/Unit	140 GPD/Unit	60 GPD/Unit
Commercial, Offices	3,600 GPD/Acre	2,160 GPD/Acre	1,440 GPD/Acre
Parks	4,000 GPD/Acre	600 GPD/Acre	3,400 GPD/Acre
Schools	60 GPD/Student	36 GPD/Student	24 GPD/Student
Industrial (Light)	4,000 GPD/Acre	2,800 GPD/Acre	1,200 GPD/Acre
Commercial / Industrial	120 GPD/1,000 SF	72 GPD/1,000 SF	48 GPD/1,000 SF
Commercial / Residential	144 GPD/1,000 SF	100 GPD/1,000 SF	44 GPD/1,000 SF
Resort	420 GPD/Unit or 4,800 GPD/Acre	294 GPD/Unit or 3,360 GPD/Acre	126 GPD/Unit or 1,440 GPD/Acre
Agriculture	4,000 GPD/Acre	667 GPD/Acre	3,333 GPD/Acre
Golf Courses	4,000 GPD/Acre	-	4,000 GPD/Acre
Landscaping	4,000 GPD/Acre	-	4,000 GPD/Acre

Source: BWS Dual Water System Demands Confirmation Study

1. *DOH Reuse Guidelines* require Recycled Water Manager for all recycled water uses including single family land use.

DIVISION 600 – NON-POTABLE WATER SYSTEM STANDARDS

B. Non-potable Demand Factors.

Table 601-02 lists the Non-potable demand factors.

Table 601-02 DEMAND FACTORS		
LAND USE	MAXIMUM DAILY DEMAND	PEAK HOUR DEMAND
<u>TYPE I</u> Golf courses, urban areas and agricultural lands with on-site storage, or uses such as cooling towers that can receive reclaimed water over a 24-hour period	1.0 × Average Demand	1.0 × Average Demand
<u>TYPE II</u> Urban areas with no on-site storage that will rely upon BWS storage, and have a 12-hour irrigation window	1.5 × Average Demand	3.0 × Average Demand

C. Pipeline Sizing.

For sizing of pipelines, a demand factor of 1.0 to 3.0 × average demand shall be utilized per Table 601-02.

1. A maximum velocity of 6 feet per second shall be utilized, unless otherwise approved by the Manager.
2. Standard Non-potable water main diameter shall be 4, 6, 8, 12, 16, 20, 24, 30, 36 and 42 inches.
3. Unless specified otherwise, maximum static or pumping pressure, whichever is greater, shall not exceed 125 psi.
4. Pressure requirements should be based on system design and practice. Customer’s operations must not cause the system’s peak hour condition to drop below a residual pressure of 20 psi, unless otherwise approved by the Manager.
5. In determining the carrying capacity of the mains, the C values to be applied as specified in Table 100-20, Water System Standard.
6. Minimum diameter of influent-effluent line from booster pump to reservoir shall be 12 inches.

D. Storage Capacity.

A factor of 1.0 x Average Daily Demand is to be used for storage sizing. This sizing criteria deviates from the Water System Standards, which require a factor of 1.5 x Average Daily Demand.

DIVISION 600 – NON-POTABLE WATER SYSTEM STANDARDS

The reservoir sizing criteria is based on:

1. Meet Average Daily Demand. Reservoir full at the beginning of the 24-hour period with no source input to the reservoir.
2. Minimum size reservoir shall be 0.1 MG. Size of reservoir shall be designed to store enough water to ensure a reliable supply of water and to maintain adequate pressures and an economical water system. Unless otherwise approved, standard sizes shall be 0.10 MG, 0.20 MG, 0.25 MG, 0.30 MG, 0.50 MG, and 1.0 MG; thereafter, sizes shall be in multiples of 0.50 MG.
3. Storage for fire protection is not required. The use of Non-potable water for fire protection is not considered when accounting for storage capacity.

E. Pump Capacity.

Pump capacity for each site shall be based on the following criteria:

1. Meet maximum day demand with an operating time of 16 hours, with the largest pumping unit considered out of service (stand-by).

F. Reservoirs.

Reservoirs for the Non-potable water system shall meet Section 105.10 RESERVOIRS of the Water System Standards, except as noted here.

1. Selection of reservoir materials shall include consideration of Non-potable water properties and provide necessary corrosion protection.
2. Overflow or draining of the reservoir to an approved drainage system shall be handled in accordance with the latest DOH guidelines.
3. To discharge Non-potable water into receiving State water, proper regulatory (DOH and/or ENV) permits and approvals shall be obtained.

DIVISION 600 – NON-POTABLE WATER SYSTEM STANDARDS

SECTION 602 – NON-POTABLE WATER MASTER PLAN

602.01 GENERAL

A Non-potable water master plan is defined as a plan describing the development of any property including the proposed Non-potable water system improvements to provide Non-potable water service to the development. All proposed work shown on the Non-potable water master plan submitted to the Manager for approval shall be designed according to the *Non-potable Water System Standards*.

602.02 PLANS

The Non-potable water master plan shall be incorporated into the water master plan and shall meet Section 113.02 PLANS of the *Water System Standards*.

DIVISION 600 – NON-POTABLE WATER SYSTEM STANDARDS

SECTION 603 – NON-POTABLE WATER OFF-SITE FACILITIES
(BWS CONTROLLED FACILITIES)

603.01 GENERAL.

Section 603 describes requirements relating to the planning and design criteria of Non-potable water off-site facilities. The term Off-Site Facilities shall mean facilities under the control of the Board of Water Supply including but not limited to Non-potable water pipelines, reservoirs, pumping stations, manholes, valves, connections, treatment facilities, natural treatment systems and other appurtenances and property up to the point of connection with the customer's facilities.

603.02 DISTRIBUTION OF NON-POTABLE WATER.

A. Transmission Pipelines. Transmission pipelines shall comply with Volume II, Section F, 1. "Transmission lines" of the latest edition of the DOH *Reuse Guidelines* except as noted here.

1. Pipe color and identification are as described in Section 603.07 PIPELINE AND APPURTENANCE IDENTIFICATION MATERIALS.
2. For system layout, all major demand areas should be serviced by an arterial-loop system. High demand areas served by distribution mains should be tied to an arterial-loop system to form a grid without dead-end mains.
3. Dead-ends should be minimized by looping mains whenever possible. Dead-ends should terminate with an approved flushing device (blowoff).

To discharge Non-potable water into receiving State water, proper regulatory (DOH and/or ENV) permits and approvals shall be obtained.

B. Pumping Facilities. Pumping facilities shall comply with Volume II, Section F. "Distribution System" of the latest edition of the DOH *Reuse Guidelines* except as noted here.

1. Pipe color and identification are as described in Section 603.07 PIPELINE AND APPURTENANCE IDENTIFICATION MATERIALS.
2. The design of Non-potable water pump stations shall either conform with the *Water System Standards* or Chapter 30 "Design Standards" of the Division of Wastewater Management Volume 1.

603.03 COVER.

Minimum depth of cover of invert grades of Non-potable water mains shall comply with Section 102.03 COVER of the *Water System Standards*.

DIVISION 600 – NON-POTABLE WATER SYSTEM STANDARDS

603.04 SEPARATION.

The minimum horizontal and vertical clearances between Non-potable water pipelines and other utilities shall comply with the requirements of Section 102.01 LOCATION of the *Water System Standards*.

603.05 JACKETING.

Concrete jacketing shall comply with Section 102.06 JACKETS of the *Water System Standards*, except as noted here.

1. Plastic pipes shall not be jacketed, unless otherwise approved by the Manager. Ductile iron pipe and fittings shall be used for the portion to be jacketed.
2. Reinforced concrete jacket is acceptable to encase RO PVC pipe using BWS WSS Detail B1 if bell and spigot joints are provided at 2' spacing on each side of the jacket. See Detail NP10.

603.06 PIPELINE MATERIALS.

Pipeline materials for Non-potable water use shall comply with requirements of the *Water System Standards* unless otherwise specified or approved by the Manager. Pipeline materials for Non-potable water use shall comply with requirements for color/identification as specified in Section 603.07 PIPELINE AND APPURTENANCE IDENTIFICATION MATERIALS.

A. PVC Pipe.

1. Pipe:

a. For R-1 and Brackish Water:

PVC pipe is required if one of the following conditions are present and the maximum static pressure does not exceed 100 psi or is approved by the Manager.

- 1) The invert of the pipe is at mean sea level elevation of +5-feet or lower.
- 2) The average soil resistivity for the project is less than 500 ohm-cm. Average soil resistivity shall be based on laboratory soil resistivity testing performed on soil samples taken along the main alignment at a maximum of 300 feet on center, and at the invert of the main.
- 3) Mains 4-inch through 12-inch in diameter, DR14 only.
- 4) For mains installed in other types of contaminated soil or other types of

DIVISION 600 – NON-POTABLE WATER SYSTEM STANDARDS

contaminated groundwater, the type of main shall be directed by the Manager.

b. For RO Water:

PVC pipe, DR14 only, can be used for mains 4-inch through 12-inch in diameter when the static pressure is less than 100 psi.

c. Pipe material does not need to meet NSF 61 requirements.

2. **Gasket Joint:**

The gasket shall be reinforced with a steel band and meet the requirements of ASTM F477 (Required that these are EPDM gaskets.) The pipe shall have an integral bell end with a locked-in factory installed gasket and shall meet the joint requirements of ASTM D3139.

3. **Marking**

The pipe should be marked with two print lines on opposite sides of it. Both sides read “CAUTION RECLAIMED WATER - DO NOT DRINK” in intervals not to exceed 5 feet. Additional marking information is also applied. The UL, FM, and NSF designations do not apply and are not printed on reclaimed water pipes.

4. **Installation**

The pipe shall be installed in accordance with AWWA C605, Underground Installation of Polyvinyl Chloride (PVC) Pressure Pipe and Fittings for Water and AWWA Manual M23, PVC Pipe Design and Installation.

5. **Assembling the Pipe**

A depth of entry mark shall be on each spigot end to serve as a visual check for rapid, accurate joint inspection.

- 1) Remove any mud, sand, or other foreign matter from the belled and spigot ends of the pipe. Carefully clean the gasket area.
- 2) With a clean applicator (a brush or hand) lubricate the entire surface of the pipe from the spigot end to the depth of entry mark and the contact surface of the gasket with Food Brand Lubricant.
- 3) Brace the bell to avoid disturbing the already installed joints. Align the pipe, insert the spigot into the bell and push.
- 4) Do not insert past the entry mark line.

B. Ductile Iron Pipe.

1. **For R-1 and Brackish Water:**

Ductile iron pipe shall comply with requirements of Section 202 of the *Water System*

DIVISION 600 – NON-POTABLE WATER SYSTEM STANDARDS

Standards, except as follows:

Include a purple polyethylene wrap to seal out water. Installation of the purple polyethylene wrap should be as described in Section 603.13 CORROSION CONTROL.

Pipe material does not need to meet NSF 61 requirements.

2. For RO Water:

Ductile iron pipe is not acceptable for RO Water.

C. High Density Polyethylene (HDPE) Pipe.

1. For R-1, RO and Brackish Water:

HDPE pipe shall conform to ductile iron outside diameter size and Pressure Class 200 (DR 9) and comply with requirements of AWWA C906, except as follows:

Pipe material does not need to meet NSF 61 requirements.

D. Stainless Steel (SS) Pipe.

Pipe and fittings shall be Type 316L Stainless Steel. Exposed surface coating shall be purple, Pantone 512 or equal.

603.07 PIPELINE AND APPURTENANCE IDENTIFICATION MATERIALS.

Pipeline identification materials shall comply with Volume II, Section H, BMPs-Component Identification of the latest edition of the DOH *Reuse Guidelines*, except as noted here.

Pipeline location identification materials, such as electronic markers, shall be placed along the pipeline alignment at locations specified by the Board of Water Supply. Electronic markers should be colored purple. Installation of electronic markers, shall comply with the Board of Water Supply's electronic markers requirements.

All new buried transmission piping in the Non-potable water system, including service lines, valves, and other appurtenances shall be colored purple, suggested color Pantone 512 or equal, and embossed or be integrally stamped/marked "CAUTION: NON-POTABLE WATER - DO NOT DRINK," or be installed with a purple identification tape, or a purple polyethylene wrap, suggested color index 77742 violet #16, Pantone 512 or equal.

Identification tape shall be minimum 4mil overall thickness of polyethylene film formulated to resist degradation due to acid and alkaline soils and prepared with white or black printing on a purple field, suggest color index 77742 violet #16, Pantone 512 or equal, having the words "CAUTION: NON-POTABLE WATER - DO NOT DRINK." The overall width of the tape shall be at least six (6) inches. Identification tapes shall be installed on top of new transmission pipe

DIVISION 600 – NON-POTABLE WATER SYSTEM STANDARDS

longitudinally and shall be centered. The identification shall be continuous in their coverage on the pipe and shall be fastened to each pipe length no more than ten feet apart. Tape attached to sections of pipe before they are placed in the trench shall have flaps sufficient for continuous coverage. Other satisfactory means of securing the tape during backfill of the trench may be used if suitable for the work, as determined by the BWS.

603.08 VALVES AND APPURTENANCES.

Main valves shall comply with Section 103 – MAIN VALVES of the *Water System Standards* except as noted here.

Resilient-Seated Gate Valves (RSGV) up to 16” shall be used for non-potable water system.

Butterfly valves may be used where there are any restrictions preventing the use of RSGVs, such as inadequate space, shallow cover, potential sediment issue of R-1, or as determined by the Manager. Butterfly valve sizes from 8” to 20” may be used. Valve spacing requirements shall be as set forth for water, except as noted herein.

A. Butterfly Valves.

Butterfly valves shall be single flange, lug body style conforming in all respects with AWWA C504, Class 150B. All valves shall be appropriate for use with ANSI 125 or 150 pound flanges or mechanical joint conforming to ASME/AWWA C111/A21.11. Bodies shall be Cast Iron, ASTM A126 Class B. Valves shall be rated at 225 psi and provide drip-tight shutoff at differential up to 225 psi. Lug body valves shall have a retained seat and shall provide tight shutoff up to the full valve rating on dead end or isolation service without the use of downstream flanges. Discs shall be offset to provide uninterrupted 360-degree seating. Discs shall be 316 stainless steel, ASTM A743, Type CF8M. The disc to shaft connections shall be 316 stainless steel. All valves shall be furnished with three self-lubricating bearings of PTFE coated stainless steel for smooth, low torque operation. Shaft seals shall be provided to prevent leakage and to protect bearings from internal and external corrosion. Each valve shall be furnished with a valve box and extension stem.

Seats shall be reinforced resilient type and shall be field replaceable. Seats shall also act as a body liner to prevent flow from contacting the body casting. Seats shall be of EPDM, which shall have properties of epoxy coating for use with demineralized water. Gaskets should be EPDM for RO water applications. Shafts shall be one piece and shall be 316 stainless steel ASTM A276. Shaft diameter shall meet the 75B standard from AWWA C504 for butterfly valves. Shafts must be finish ground to minimize bearing and shaft wear. Shafts of 16-inches and larger valves shall have a non-adjustable thrust collar.

Interiors of butterfly valves shall be lined with epoxy coating unless otherwise approved by the Manager.

DIVISION 600 – NON-POTABLE WATER SYSTEM STANDARDS

B. Actuators.

Actuators specified for potable water service are acceptable for recycled water, except as noted here. A geared actuator appropriate for buried service shall operate all valves. Gear housing shall be furnished with 316 stainless steel bolting and a 2-inch square AWWA nut input. All units shall have adjustable open and closed stop positions with provision to prevent accidental adjustment changes. All actuators shall provide external indication of disc position. Actuators shall be operable with maximum effort not to exceed 40 pounds and shall be sized for the full pressure rating of the valve.

C. Fittings for underground piping.

1. For R-1 and Brackish Water:

Fittings for underground piping suitable for potable water service are acceptable for R-1 and Brackish Water, except as noted here. Ductile iron fittings are appropriate for R-1 and Brackish Water.

2. For RO Water:

Fittings for underground piping suitable for R-1 and Brackish Water are acceptable for RO Water, except as noted here. Ductile iron fittings shall meet requirements of AWWA C111 and AWWA C115. All fittings' interiors and exteriors shall be lined with epoxy coating.

D. Fittings for aboveground piping.

1. For R-1 and Brackish Water

Fittings for aboveground piping suitable for potable water service are acceptable for R-1 and Brackish Water.

2. For RO Water

Fittings for aboveground piping suitable for potable water service are acceptable for RO Water, except as noted here. 316L stainless steel fittings or steel with epoxy coating on interior surfaces.

603.09 VALVE BOX, CASTINGS AND COVER IDENTIFICATION.

Non-potable water valve box and covers shall conform with the *Water System Standards* and Volume II, Section H. BMPs – Component Identification of the latest version of the *DOH Reuse Guidelines*, in addition to the following:

Valve box covers shall be permanently marked “NON-POTABLE WATER” and painted or integrally colored purple (Pantone 512, or equal). Covers shall be affixed to valve box by proof coil chain.

DIVISION 600 – NON-POTABLE WATER SYSTEM STANDARDS

Type X valve box cover material shall be cast iron, fiber reinforced concrete, or composite.

603.10 COLOR-CODING EXPOSED NON-POTABLE WATER APPURTENANCES.

Color-coding exposed Non-potable water appurtenances shall comply with Volume II, Section H. BMPs – Component Identification of the latest edition of the DOH *Reuse Guidelines*, in addition to the following:

All above ground existing and new Non-potable water appurtenances shall be consistently colored purple, suggested color index 77742 violet #16, Pantone 512 or equal and marked to differentiate recycled water appurtenances from potable water or wastewater.

603.11 AIR RELEASE VALVES.

1. For R-1 and Brackish Water:

Air release valves (ARVs) specified for potable water service are acceptable for R-1 and Brackish Water but are not acceptable for RO Water.

2. For RO Water:

ARVs specified for potable water service are acceptable for RO Water, except as noted here. ARVs shall be 316L stainless steel construction. ARVs shall have a bearing area of sufficient width along the axis of the pipe; so that the pipe will not be distorted when the saddle is tightened. All ARVs shall have a working pressure of 0-65 psi or shall be as called for on the plans, unless otherwise approved by the Manager.

603.12 BLOWOFF LINES.

Where required by the Manager, blowoff lines shall be installed. The blowoff lines will normally be required on long transmission mains to provide a means for flushing out the line. The blowoff line shall be installed in such a manner and at such location as to preclude backflow.

Either an in-line type or end-of-line type drain (blow-off) assembly shall be installed for removing water or sediment from the pipe. The line tap for the assembly shall be no closer than 18-inches to a valve, coupling, joint or fitting unless it is at the end of the line. To discharge Non-potable water into receiving State water, proper regulatory (DOH and/or ENV) permits and approvals shall be obtained.

Pipe color and identification are as described in Section 603.07 PIPELINE AND APPURTENANCE IDENTIFICATION MATERIALS.

603.13 CORROSION CONTROL.

Corrosion control shall comply with Division 500 WATER SYSTEM EXTERNAL CORROSION CONTROL STANDARDS of the *Water System Standards*, except as noted here.

DIVISION 600 – NON-POTABLE WATER SYSTEM STANDARDS

Part 3. PIPE COATINGS, Section 1. REQUIREMENTS, 1.2.1 POLYETHYLENE ENCASUREMENT: Installation of the purple polyethylene encasement should be as follows:

1. Fold the wrap longitudinally and tape the wrap to the DIP along the fold.
2. Tape the ends of the encasement around circumferentially to seal out water between the wrap and the DIP.
3. Spiral wrap every 2 feet for the entire length of the pipe.
4. Bond all joints and install test stations to monitor corrosion activity.

Part 3. PIPE COATINGS, Section 2. INSPECTION/REPAIR, 2.1 GENERAL: Coatings shall be inspected and repaired by the manufacturer to a level of quality that exceeds the undamaged pipe.

Part 5. GALVANIC ANODE CATHODIC PROTECTION (GACP) SYSTEM SPECIFICATION, Section 3. EXECUTION, 3.4 TEST STATION: Test boxes in unpaved non-traffic areas shall include valve markers.

603.14 METERS AND METER BOXES.

Meter type, sizing and meter boxes for potable water service is acceptable for Non-potable water service and shall conform with the *Water System Standards*, in addition to the following:

Meter type and sizing for Non-potable water shall be coordinated with and approved by BWS.

Meter Box cover material, color, and identification are as described in Section 603.09 VALVE BOX, CASTINGS AND COVER IDENTIFICATION.

603.15 MISCELLANEOUS OFF-SITE RECYCLED WATER FACILITIES.

Off-site Recycled Water Facilities shall comply with Volume I, Recycled Water Facilities, of the latest edition of the *DOH Reuse Guidelines*.

DIVISION 600 – NON-POTABLE WATER SYSTEM STANDARDS

SECTION 604 – NON-POTABLE WATER ON-SITE FACILITIES
(NON-BWS CONTROLLED FACILITIES)

604.01 GENERAL.

Section 604 describes requirements relating to the planning and design criteria of Non-potable water on-site facilities. The term On-Site Facilities shall mean facilities under the control of the customer including but not limited to residential, commercial, and industrial building water and sewerage systems, landscape irrigation systems, and agricultural irrigation systems. For water and recycled water service, the on-site facilities shall be those downstream of the service connection, which shall normally be the downstream end of the meter tailpiece.

604.02 IDENTIFICATION OF ON-SITE PIPES, FITTINGS AND BURIED PIPELINES.

Identification of on-site facilities and pipeline identification shall comply with Volume II, Section H. BMP – Component Identification of the latest version of the DOH *Reuse Guidelines*, and as modified by Section 603.07 PIPELINE AND APPURTENANCE IDENTIFICATION MATERIALS.

604.03 SEPARATION.

The minimum horizontal and vertical clearances between Non-potable water and other utility pipelines shall comply with Section 102.01 LOCATION of the *Water System Standards*.

604.04 CROSS-CONNECTION CONTROL.

Cross-connection control shall comply with Section 305 BACKFLOW PREVENTION ASSEMBLIES of the *Water System Standards*, in addition to the following.

The installation of a BWS approved double check valve assembly (DC) shall be required after the non-potable water meter prior to any tees or branches per BWS Non-Potable Water System Standard Detail NP7.

The DC is required at the non-potable connection if the onsite facility has a booster pump, fertigation system, or any type of pressurizing system. Any future modification of pressurization (i.e., booster pump) shall be reviewed by the Department, and proper backflow prevention shall be installed as required by the Department.

The installation of the DC shall be required after the non-potable water meter prior to any tees or branches for any other reason or cause deemed sufficient in the Department's discretion.

All DCs shall be tested at least once annually, or as often as deemed necessary by the

DIVISION 600 – NON-POTABLE WATER SYSTEM STANDARDS

Department.

Facilities using non-potable water will be subject to the Department's annual cross-connection control survey or as often as deemed necessary by the Department.

Facilities using non-potable water will be subject to the Department's triennial (every three years) dye test or as often as deemed necessary by the Department.

The non-potable water system design should account for a pressure loss of approximately 5 to 7 psi or possible 10% loss in pressure depending on the make and model of the DC.

The use of quick coupling valve between the meter and backflow prevention assembly is not approved.

For RO water, use reduced pressure backflow preventers with stainless steel body.

604.05 MISCELLANEOUS ON-SITE ITEMS

On-site Recycled Water Facilities shall comply with Volume I, Recycled Water Facilities, of the latest edition of the DOH *Reuse Guidelines*.

On-Site Distribution Systems shall comply with Volume II, Section F, 2. ON-SITE DISTRIBUTION SYSTEMS of the latest edition of the DOH *Reuse Guidelines*.

604.06 SIGNAGE, DECALS, AND TAGS

Identification sign/tags informing the public of Non-potable water uses shall comply with the requirements of Volume II, Section H. BMPs - Component Identification and Appendix B: Recycled Water Project Notes of the latest edition of the DOH *Reuse Guidelines*. Location of identification signs for Non-potable water (other than recycled water) use areas shall be approved by BWS. Location of identification signs for recycled water use areas shall be approved by DOH. End user shall obtain DOH approval of recycled water use plan prior to connection to the BWS systems.

DIVISION 600 – NON-POTABLE WATER SYSTEM STANDARDS

SECTION 605 – NON-POTABLE WATER FOR OTHER USES

605.01 CONSTRUCTION USES

Non-potable water for construction may only be used for construction grading, dust control, consolidation, and compaction of backfill. The use of recycled water for construction grading, dust control, consolidation, and compaction of backfill shall be approved by DOH.

Construction uses shall meet Volume II, Section L. BMPs – Temporary Recycled Water Use of the latest edition of the DOH *Reuse Guidelines*.

DIVISION 600 – NON-POTABLE WATER SYSTEM STANDARDS

**SECTION 606 – RETROFITTING EXISTING FACILITIES FOR NON-POTABLE WATER
USES**

606.01 RETROFITTING EXISTING FACILITIES FOR NON-POTABLE WATER USES

Retrofitting existing facilities for Non-potable water usage shall meet the latest version of the DOH *Reuse Guidelines*.

DIVISION 600 – NON-POTABLE WATER SYSTEM STANDARDS

SECTION 607 – APPROVED MATERIALS LIST

Materials acceptable for potable water uses are not acceptable for RO water uses unless specified.

607.01 PIPES AND APPURTENANCES

Generally pipes and appurtenances suitable for potable water service and identified in Section 200 of the Water System Standards are applicable for Non-potable water service with the following additions and exceptions. Additional material types are HDPE and stainless steel materials.

607.02 VALVES AND APPURTENANCES

Generally valves and appurtenances suitable for potable water service and identified in Section 205 of the Water System Standards are applicable for Non-potable water service with the following additions and exceptions. Additional material types are HDPE and stainless steel materials.

607.03 SERVICE LATERALS AND APPURTENANCES

Generally service laterals and appurtenances suitable for potable water service and identified in Section 208 of the Water System Standards are applicable for Non-potable water service with the following additions and exceptions. Additional material types are HDPE and stainless steel materials.

607.04 PAINTS AND COATINGS

Generally paints and coatings suitable for potable water service and identified in the Water System Standards are applicable for Non-potable water service.

607.05 MISCELLANEOUS

Generally miscellaneous items suitable for potable water service and identified in the Water System Standards are applicable for Non-potable water service with the following additions and exceptions. Additional material types are HDPE and stainless steel materials.

DIVISION 600 – NON-POTABLE WATER SYSTEM STANDARDS APPROVED MATERIAL LIST

DESCRIPTION		APPROVED FOR		
Manufacturer	Catalog or Model No.	RO	R-1	BW
I. PIPES AND APPURTENANCES				
A. Cast Iron Pipe (Ductile), Push-On Joints, Mechanical Joints, Flanged Joints AWWA C151				
Materials identified in the Water System Standards Section 402 Approved Materials List are approved for uses as indicated to the right, with the following additional requirements:				
Pipe for underground service shall be wrapped with polywrap (see I., M.). Pipe for exposed surface shall have purple coating, Pantone 512 or equal.			0	0
American Cast Iron Pipe Company			0	0
Griffin Pipe Products, Co.			0	0
U.S. Pipe & Foundry			0	0
B. Cast Iron Fittings (Gray or Ductile) AWWA C110				
Materials identified in the Water System Standards Section 402 Approved Materials List are approved for uses as indicated to the right, with the following additional requirements:				
Pipe for underground service shall be wrapped with polywrap (see I.M). Pipe for exposed surface shall have purple coating, Pantone 512 or equal.			0	0
Fittings shall have interiors and exteriors lined with epoxy coating PPA Plascoat 571 or equal. Exterior coating shall be colored purple, Pantone 512 or equal.		0 ¹		
<i>⁽¹⁾Approved for underground service only. See I., G. for aboveground service.</i>				
American Cast Iron Pipe Company		0	0	0
Griffin Pipe Products, Co.		0	0	0
U.S. Pipe & Foundry		0	0	0
C. PVC Pipe AWWA C900				
Materials identified in the Water System Standards Section 402 Approved Materials List are approved for uses as indicated to the right, with the following additional requirements:				
Use color purple, Pantone 512 or equal.		0	0	0
CertainTeed	C900/RJ	0	0	0
VinylTech	Purple Pipe	0	0	0
JM Eagle		0	0	0

DIVISION 600 – NON-POTABLE WATER SYSTEM STANDARDS APPROVED MATERIAL LIST

<u>DESCRIPTION</u>		<u>APPROVED FOR</u>		
<u>Manufacturer</u>	<u>Catalog or Model No.</u>	<u>RO</u>	<u>R-1</u>	<u>BW</u>
E. PVC Fittings AWWA C907				
Materials identified in the Water System Standards Section 402 Approved Materials List are approved for uses as indicated to the right, with the following additional requirements:				
Use color purple, Pantone 512 or equal.		0	0	0
CertainTeed		0	0	0
VinylTech	Purple Pipe	0	0	0
JM Eagle		0	0	0
F. HDPE Pipe AWWA C906				
Colored purple, Pantone 512 or equal.		0	0	0
1. JW Eagle		0	0	0
2. ISCO Industries		0	0	0
3. Chevron Philips Chemical Company	Performance Pipe	0	0	0
G. Stainless Steel Pipe and Fittings AWWA C220, C226				
Pipe and fittings shall be Type 316L Stainless Steel. Exposed surface coating shall be purple, Pantone 512 or equal. Surface preparation of stainless steel includes sweep-blasting, scrubbing or etching the surface with steel wool. Use primer and enamel paint for stainless steel and follow manufacturer's instruction and industry standards.		0	0	0
American Piping Products		0	0	0
H. Gaskets				
Materials identified in the Water System Standards Section 402 Approved Materials List are approved for uses as indicated to the right, with the following additional requirements:				
EPDM gaskets for pipe couplings, tapping sleeves, glands, and flanged adapters.		0	0	0
U.S. Pipe & Foundry	FLANGE-TYTE	0	0	0
Garlock	Premium Rubber-EPDM	0	0	0
Romac Industries	Flange Style-EPDM	0	0	0

DIVISION 600 – NON-POTABLE WATER SYSTEM STANDARDS APPROVED MATERIAL LIST

DESCRIPTION		APPROVED FOR		
Manufacturer	Catalog or Model No.	RO	R-1	BW
I. Sheet Packing (Gasket Material)				
Materials identified in the Water System Standards Section 402 Approved Materials List are approved for uses as indicated to the right, with the following additional requirements:				
Gaskets shall be EPDM.		0	0	0
U.S. Pipe & Foundry	FLANGE-TYTE	0	0	0
Garlock	Blue-Gard Style 3000, as “an equal” to asbestos for Stockham cast iron valves	0	0	0
Romac Industries	Flange Style-EPDM	0	0	0
J. Couplings - Pipelines				
Materials identified in the Water System Standards Section 402 Approved Materials List are approved for uses as indicated to the right, with the following additional requirements:				
No additional requirements			0	
Ductile Iron interiors and exteriors shall be lined with epoxy coating PPA Plascoat 571 or equal. Gaskets shall be EPDM.		0		0
Cascade Manufacturing	433, 441	0	0	0
JCM	No. 301 Flanged Coupling Adapter	0	0	0
Powerseal Pipeline Products	3501, 3504, 3521MJ, 3541RT	0	0	0
Romac Industries	Style 501	0	0	0
K. Tapping Sleeves				
Materials identified in the Water System Standards Section 402 Approved Materials List are approved for uses as indicated to the right, with the following additional requirements:				
Gaskets shall be EPDM.		0	0	0
American Flow Control	M.J. Split Tapping Sleeve	0	0	0
Cascade Co.	Stainless Steel Split Tapping Sleeve Style 600	0	0	0
Clow Corp.	MJ Tapping Sleeve, F-5093	0	0	0
Clow Corp.	MJ Tapping Sleeve, F-5205	0	0	0
Kennedy	Squareseal Tapping Sleeve	0	0	0
M&H Valve and Fitting Co.	Catalog 52, Fig. 74-75	0	0	0

DIVISION 600 – NON-POTABLE WATER SYSTEM STANDARDS APPROVED MATERIAL LIST

<u>DESCRIPTION</u>		<u>APPROVED FOR</u>		
<u>Manufacturer</u>	<u>Catalog or Model No.</u>	<u>RO</u>	<u>R-1</u>	<u>BW</u>
M&H Valve and Fitting Co.	Catalog 52, Style 974	0	0	0
Mueller Co.	Model H-615	0	0	0
Mueller Co.	Model H-616	0	0	0
Mueller Co.	Model H-619, for maximum working pressure of 150 psi	0	0	0
Mueller Co.	Model H-667	0	0	0
Powerseal Pipeline Products	3480	0	0	0
Powerseal Pipeline Products	3490	0	0	0
Romac Industries	"SST" Stainless Steel Tapping Sleeve	0	0	0
U.S. Pipe	Mechanical Joint Tapping Sleeve	0	0	0
L. Gland				
Materials identified in the Water System Standards Section 402 Approved Materials List are approved for uses as indicated to the right, with the following additional requirements:				
Gaskets shall be EPDM.		0	0	0
EBAA	#9106 Series 600, 6-inch DI and accessories	0	0	0
Standard Water Works Equipment Co.,	Mechanical joint retainer glands and Kwik-Flanges	0	0	0
U.S. Pipe	Ductile Iron Segmented Mechanical Joint 24" through 48"	0	0	0
U.S. Pipe	Lightweight ductile Iron Mechanical Joint 8" through 12", conforms to section 11-10 of the AWWA C111-90	0	0	0
M. Polywrap				
Materials identified in the Water System Standards Section 402 Approved Materials List are approved for uses as indicated to the right, with the following additional requirements:				
Colored purple, Pantone 512 or equal.		0	0	0
Northtown Company	Polyethylene Material	0	0	0
Repcor, Inc.	Polyethylene Material	0	0	0

DIVISION 600 – NON-POTABLE WATER SYSTEM STANDARDS APPROVED MATERIAL LIST

DESCRIPTION		APPROVED FOR		
Manufacturer	Catalog or Model No.	RO	R-1	BW
N. Flanged Adapters				
Materials identified in the Water System Standards Section 402 Approved Materials List are approved for uses as indicated to the right, with the following additional requirements:				
Gaskets shall be EPDM.		0	0	0
Baker	Series 601	0	0	0
Dresser	Model 227	0	0	0
JCM Industries	Steel flange coupling adaptor No. 303, Cast/ductile iron composition is required.	0	0	0
Mueller Co.	Viking-Johnson FLxFL Dismantling Joint, with 316 SS bolts, and NSF 61 approved coating for components	0	0	0
Romac Industries, Inc.	Style FCA 501	0	0	0
Smith-Blair	Series 912, w/thicker gasket, 1” longer bolts & increased stainless steel band cutting width to accommodate thicker gasket	0	0	0
O. Plugs; Brass				
Materials identified in the Water System Standards Section 402 Approved Materials List are approved for uses as indicated to the right.			0	0
No additional requirements.				
McDonald Co.	Sect. 3, Models 3206, 3208			
Mueller Co.	Catalog W-103, Model H-10033		0	0

DIVISION 600 – NON-POTABLE WATER SYSTEM STANDARDS APPROVED MATERIAL LIST

<u>DESCRIPTION</u>		<u>APPROVED FOR</u>		
<u>Manufacturer</u>	<u>Catalog or Model No.</u>	<u>RO</u>	<u>R-1</u>	<u>BW</u>
II. VALVES AND APPURTENANCES				
A. Air Relief Valves/Combination Air Valves (ARV), Low Pressure (0-150 psi)				
Materials identified in the Water System Standards Section 402 Approved Materials List are approved for uses as indicated to the right, with the following additional requirements:				
ARV's for exposed service shall have purple coating Pantone 512 or equal.			0	0
ARV's for exposed service shall have purple coating Pantone 512 or equal. Stainless Steel Body (316L), Gaskets shall be EPDM.		0		
APCO Willamette (Valve & Primer Corporation)	Catalog 726, Bulletin 600, Model 65 with 3/4" inlet and 1/8" orifice, working pressure 0-150 psi	0	0	0
APCO Willamette (Valve & Primer Corporation)	Catalog 726, Bulletin 600, Model 200 with 2" inlet and 3/8" orifice, working pressure 0-150 psi	0	0	0
Armstrong Machine Works	1-AV with 3/4" inlet, working pressure 0-150 psi	0	0	0
Fisher Automatic Air Vent Traps	Type 30, with 2" inlet and 3/8" orifice, working pressure 0-100 psi	0	0	0
GA Industries	Figure 912, with 3/4" inlet and 1/8" orifice	0	0	0
Multiplex Manufacturing Company, Crispin Pressure Air Valves	P20 with 2" inlet and 3/8" orifice, working pressure 0-100 psi	0	0	0
Multiplex Manufacturing Company, Crispin Pressure Air Valves	P20 with 2" inlet and 5/16" orifice, working pressure 0-150 psi	0	0	0
Multiplex Manufacturing Company, Crispin Pressure Air Valves	Midget M-8 with 3/4" inlet and 1/8" orifice, working pressure 0-150 psi	0	0	0
Val-Matic Valve & Manufacturing	No. 25.5 with 3/4" inlet, working pressure 0-150 psi, 1/8" orifice	0	0	0
Val-Matic Valve & Manufacturing	No. 38.2 with 2" inlet, working pressure 0-150 psi, orifice 1/4" for pipes 20" to 30", orifice 3/8" for pipes 36" and larger	0	0	0
Val-Matic Valve & Manufacturing	No. 45 with 2" inlet, working pressure 0-150 psi, orifice 1/4" for pipes 20" to 30", orifice 3/8" for pipes 36" and larger	0	0	0

DIVISION 600 – NON-POTABLE WATER SYSTEM STANDARDS APPROVED MATERIAL LIST

<u>DESCRIPTION</u>		<u>APPROVED FOR</u>		
<u>Manufacturer</u>	<u>Catalog or Model No.</u>	<u>RO</u>	<u>R-1</u>	<u>BW</u>
B. Gate Valves, 4" and Larger				
1. 150-Pound Valves				
Materials identified in the Water System Standards Section 402 Approved Materials List are approved for uses as indicated to the right, with the following additional requirements:				
Valves for underground service shall be wrapped with polywrap (see I., M.). Valves for exposed surface shall have purple coating, Pantone 512 or equal. Interiors shall be lined with epoxy coating PPA Plascoat 571 or equal. Wedge shall be covered with EPDM. Gaskets shall be EPDM.		0	0	0
A.P. Smith	V-56-10M, metropolitan series 3000 in sizes 14" to 48" incl.	0	0	0
American Flow Control		0	0	0
Clow Corp.	Book 91, Model F-5062, Hub end	0	0	0
Clow Corp.	Book 91, Model F-5065, MJ	0	0	0
Clow Corp.	Book 91, Model F-5070, FE	0	0	0
Clow Corp.	Book 91, Model F-5080 in sizes 14" thru 48", Push on	0	0	0
Kennedy Valve Mfg. Co	Cat. 94A, Model 561, FE	0	0	0
Kennedy Valve Mfg. Co	Cat. 94A, Model 571, MJ	0	0	0
Kennedy Valve Mfg. Co	Cat. 94A, Model 572, MJ x FE	0	0	0
Mueller Co.	Cat. E1, Model A-2380-6, FE	0	0	0
Mueller Co.	Cat. E1, Model A-2380-16, MJ x FE	0	0	0
Mueller Co.	Cat. E1, Model A-2380-20, MJ	0	0	0
Mueller Co.	Cat. E1, Model A-2380-38	0	0	0
Mueller Co.	Cat. E1, Model A-2380-41	0	0	0
Mueller Co.	Cat. E1, Model A-2380-48	0	0	0
Mueller Co.	Cat. E1, Model A-2483-6 in sizes 14" to 48"	0	0	0
Stockham	Catalog 83, Model G-743-0	0	0	0
Stockham	Catalog 83, Model G-745-0	0	0	0
Stockham	Catalog 83, Model G-746-0	0	0	0
Stockham	Catalog 83, Model G-747-0 in sizes 14" to 16"	0	0	0

DIVISION 600 – NON-POTABLE WATER SYSTEM STANDARDS APPROVED MATERIAL LIST

<u>DESCRIPTION</u>		<u>APPROVED FOR</u>		
<u>Manufacturer</u>	<u>Catalog or Model No.</u>	<u>RO</u>	<u>R-1</u>	<u>BW</u>
<p>2. 200-Pound Valves</p> <p>Materials identified in the Water System Standards Section 402 Approved Materials List are approved for uses as indicated to the right, with the following additional requirements:</p>				
<p>Valves for underground service shall be wrapped with polywrap (see I.M.). Valves for exposed surface shall have purple coating, Pantone 512 or equal. Interiors shall be lined with epoxy coating PPA Plascoat 571 or equal. Wedge shall be covered with EPDM. Gaskets shall be EPDM.</p>		0	0	0
A.P. Smith	V-56-10M Metropolitan Series 3000 in sizes 4" to 12" incl.		0	0
Clow Corp.	List 16 extra heavy pressure gate valve in sizes 24" to 30"		0	0
Clow Corp.	Model F-5062		0	0
Clow Corp.	Model F-5065, MJ		0	0
Clow Corp.	Model F-5066, MJ X FE		0	0
Clow Corp.	Model F-5070, FE		0	0
Clow Corp.	Model F-5072, FE-OS&Y		0	0
Clow Corp.	Model F-5080 in sizes 4" thru 12"		0	0
Kennedy Valve Mfg. Co.	Catalog No. 94A, Model 561, FE		0	0
Kennedy Valve Mfg. Co.	Catalog No. 94A, Model 571, MJ		0	0
Kennedy Valve Mfg. Co.	Catalog No. 94A, Model 572MJ X FE		0	0
Stockham	Catalog 83, Model G-743-0		0	0
Stockham	Catalog 83, Model G-745-0		0	0
Stockham	Catalog 83, Model G-746-0		0	0
Stockham	Catalog 83, Model G-747-0 in sizes 4" to 12"		0	0
<p>3. 250-Pound Valves</p> <p>Materials identified in the Water System Standards Section 402 Approved Materials List are approved for uses as indicated to the right, with the following additional requirements:</p>				

DIVISION 600 – NON-POTABLE WATER SYSTEM STANDARDS APPROVED MATERIAL LIST

<u>DESCRIPTION</u>		<u>APPROVED FOR</u>		
<u>Manufacturer</u>	<u>Catalog or Model No.</u>	<u>RO</u>	<u>R-1</u>	<u>BW</u>
Valves for underground service shall be wrapped with polywrap (see I.M.). Valves for exposed surface shall have purple coating, Pantone 512 or equal. Wedge shall be covered with EPDM. Gaskets shall be EPDM. Valve shall be coated with epoxy internally.		0	0	0
Clow Corp.	16 Extra Heavy Pressure Gate Valve 4" to 20"	0		
Kennedy Valve Mfg. Co.	Catalog 94A, Model 561, FE	0		
Kennedy Valve Mfg. Co.	Catalog 94A, Model 571, MJ	0		
Kennedy Valve Mfg. Co.	Catalog 94A, Model 572X all extra heavy Class 250, MJ x FE	0		
4. Resilient Wedge (AWWA C509)				
Materials identified in the Water System Standards Section 402 Approved Materials List are approved for uses as indicated to the right, with the following additional requirements:				
Valves for underground service shall be wrapped with polywrap (see I., M.). Valves for exposed surface shall have purple coating, Pantone 512 or equal.			0	
Valves for underground service shall be wrapped with polywrap (see I., M.). Valves for exposed surface shall have purple coating, Pantone 512 or equal. Interiors shall be lined with epoxy coating PPA Plascoat 571 or equal. Wedge shall be covered with EPDM. Gaskets shall be EPDM.		0		0
Clow Corp.	Sizes 4" thru 12" Series 6100	0		
Kennedy Valve Mfg. Co.	Ken-Seal II Series 4000 (3"-12")	0		
Mueller	Model A2360 Resilient Wedge	0		
Stockham	Resilient Wedge	0		
U.S. Pipe & Foundry Co.	Metroseal 250, 4" thru 20", 250 psi	0		
C. Butterfly Valves and Manual Operators for underground service (All valves and operators shall be subject to Manager's approval)				
1. Butterfly Valves				
a. Butterfly Valves for R-1 and Brackish Service				
Materials identified in the Water System Standards Section 402 Approved Materials List are approved for uses as indicated to the right, with the following additional requirements:				
Valves for underground service shall be wrapped with polywrap (see I.M.). Valves for exposed surface shall have purple coating, Pantone 512 or equal. Interiors lined with epoxy coating PPA Plascoat 571 or equal.			0	0

DIVISION 600 – NON-POTABLE WATER SYSTEM STANDARDS APPROVED MATERIAL LIST

<u>DESCRIPTION</u>		<u>APPROVED FOR</u>		
<u>Manufacturer</u>	<u>Catalog or Model No.</u>	<u>RO</u>	<u>R-1</u>	<u>BW</u>
(BIF Industries) Dezurik		0		
Crane Co. (Stockham)	(Not full body / wafer)	0		
Kennedy Valve Company	Catalog BFV-77, Model ADAP-TORQ	0		
Kennedy Valve Company	Model 30A & 50A shall be used w/approved 90-deg. operator	0		
M&H	Style 1450 (30"-48")	0		
M&H	Style 4500 (4"-24")	0		
Mueller Company	Model B3211-6,FE	0		
b. Butterfly Valves for RO Service				
Valves shall conform to Non-potable Water Standard Section 603.09				
1. DeZurik	BOS-US	0		
2. Crane Co. (Stockholm)		0		
3. Bray Controls	Series 31H lug	0		
2. Manual Operator				
Materials identified in the Water System Standards Section 402 Approved Materials List are approved for uses as indicated to the right.		0	0	0
American Flow Control			0	0
Clow Corp.			0	0
Kenneth Elliot Company			0	0
Kennedy Valve Company			0	0
M&H			0	0
Mueller Company	"Linesal III"	0		
Philadelphia Gear Corporation			0	0
D. Service Valves, 3" and Smaller				
Materials identified in the Water System Standards Section 402 Approved Materials List are approved for uses as indicated to the right.			0	0
American	Model 27-FE		0	0
American	Model 27-M-MJ		0	0

DIVISION 600 – NON-POTABLE WATER SYSTEM STANDARDS APPROVED MATERIAL LIST

<u>DESCRIPTION</u>		<u>APPROVED FOR</u>		
<u>Manufacturer</u>	<u>Catalog or Model No.</u>	<u>RO</u>	<u>R-1</u>	<u>BW</u>
American	Model 28-HF		0	0
American	Model 28-H-RT		0	0
Crane Co.	Model 438, Bronze		0	0
Fairbanks	Model 250		0	0
Hammond Valve Corp.	Model 645		0	0
Kennedy	Catalog 86, Model 427		0	0
Kitz Valves	Model AKH27		0	0
Milwaukee Valve Co.	Models 105, 1104, 1105		0	0
Nibco	Models T-113		0	0
Ohio Brass Co.	Model 2500		0	0
Ohio Injector Company	Model 7108		0	0
Powell Co.	Catalog 11, Model 507		0	0
Red-White Valve Corp.			0	0
(Stockham) Crane Co.	Catalog 57, Model B-115		0	0
Walworth	Catalog 52, Model 4		0	0
E. Check Valves				
1. Vertical Check Valves				
Materials identified in the Water System Standards Section 402 Approved Materials List are approved for uses as indicated to the right.			0	0
Kennedy Valve Manufacturing Co.	Catalog 86, Model 490	0		
Ohio Brass Co.	Model 104	0		
2. Swing Check Valves				
a. 125-pound				
Materials identified in the Water System Standards Section 402 Approved Materials List are approved for uses indicated at right.			0	0
Fairbanks	Model 0640 & 0642	0		
Lunkenheimer	Catalog 66, Model 2144	0		
A.Y. McDonald Mfg Co.	2050T	0		
Milwaukee	Catalog C-161, Model 509	0		

DIVISION 600 – NON-POTABLE WATER SYSTEM STANDARDS APPROVED MATERIAL LIST

<u>DESCRIPTION</u>		<u>APPROVED FOR</u>		
<u>Manufacturer</u>	<u>Catalog or Model No.</u>	<u>RO</u>	<u>R-1</u>	<u>BW</u>
Nibco	Models T-413-B	0		
Ohio Brass Co.	Models 106 & 806	0		
Stockham	Catalog 57, Model B-319	0		
Walworth	Catalog 52, Model 406	0		
b. 200-pound				
Materials identified in the Water System Standards Section 402 Approved Materials List are approved for uses indicated at right.			0	0
Crane	Model 36	0		
Lunkenheimer	Catalog 66, Model 554	0		
Nibco	T-453-B	0		
Ohio Brass Co.	Model 806	0		
Stockham	Catalog 57, Model B-345	0		
Walworth	Catalog 52, Model 420	0		
c. Stainless Steel, 3 inches and greater				
1. Aloyco	Figure 377	0	0	0
2. Powell Valves	Figure 2342 or 2633	0	0	0
3. Horizontal Lift Check Valves (200-pound)				
Materials identified in the Water System Standards Section 402 Approved Materials List are approved for uses indicated at right.			0	0
Fairbanks	Model 0608	0		
Lunkenheimer	Catalog 66, Model 414	0		
F. Valve Box, Castings (shall conform with Standard Details)				
Materials identified in the Water System Standards Section 402 Approved Materials List are approved for uses as indicated to the right, with the following additional requirements:				
Colored purple, Pantone 512 or equal.		0	0	0
G. Manhole Castings (shall conform with Standard Details)				

DIVISION 600 – NON-POTABLE WATER SYSTEM STANDARDS APPROVED MATERIAL LIST

<u>DESCRIPTION</u>		<u>APPROVED FOR</u>		
<u>Manufacturer</u>	<u>Catalog or Model No.</u>	<u>RO</u>	<u>R-1</u>	<u>BW</u>
Materials identified in the Water System Standards Section 402 Approved Materials List are approved for uses as indicated to the right, with the following additional requirements:				
Colored purple, Pantone 512 or equal.		0	0	0

DIVISION 600 – NON-POTABLE WATER SYSTEM STANDARDS APPROVED MATERIAL LIST

<u>DESCRIPTION</u>		<u>APPROVED FOR</u>		
<u>Manufacturer</u>	<u>Catalog or Model No.</u>	<u>RO</u>	<u>RI</u>	<u>BW</u>
III. SERVICE LATERALS, FITTINGS AND APPURTENANCES				
A. Ball Corps				
Materials identified in the Water System Standards Section 402 Approved Materials List are approved for uses indicated at right.			0	0
Ford Meter Box Co., Inc.	FB 800, 2 ½" x 2"	0 ¹		
James Jones	J-1944 (Hawaii)	0 ¹		
A.Y. McDonald Mfg. Co.	3128B	0 ¹		
Mueller Co.	B-2996	0 ¹		
¹ Stainless Steel only				
B. Service Lateral Fittings				
Materials identified in the Water System Standards Section 402 Approved Materials List are approved for uses indicated at right.			0	0
American Brass Co.	"Anaconda"	0 ¹		
Elkhart Products Corp.	Cast bronze threaded fittings, Cast copper alloy fittings for flared copper tube, bronze pipe flanges and flanged fittings		0	0
Lee Brass Company	Cast threaded fittings		0	0
A.Y. McDonald Mfg. Co.	Mac-Pak 4753-22		0	0
A.Y. McDonald Mfg. Co.	Mac-Pak 4754-22		0	0
A.Y. McDonald Mfg. Co.	Mac-Pak 4758-22		0	0
Mueller Co.	"Streamline"		0	0
NIBCO				
Phelps-Dodge Copper Products	"P-D"		0	0
¹ Stainless Steel only				
C. Ball Stops				
Materials identified in the Water System Standards Section 402 Approved Materials List are approved for uses indicated at right.			0	0
Ford Meter Box Co. Inc.	Model B11(R)	0 ¹		
James Jones Co.	Catalog J, Model J-1900W Series	0 ¹		

DIVISION 600 – NON-POTABLE WATER SYSTEM STANDARDS APPROVED MATERIAL LIST

<u>DESCRIPTION</u>		<u>APPROVED FOR</u>		
<u>Manufacturer</u>	<u>Catalog or Model No.</u>	<u>RO</u>	<u>RI</u>	<u>BW</u>
James Jones Co.	Model J-1944-LP	0 ¹		
A. Y. McDonald Mfg. Co.	6111	0 ¹		
Mueller Co.	B20283-3 (w/ lock wings, for Oahu only), B25209R-3	0 ¹		
¹ Stainless Steel only				
D. Ball Meter Valves				
Materials identified in the Water System Standards Section 402 Approved Materials List are approved for uses indicated at right.			0	0
Ford Meter Box Co., Inc.	Model B13	0 ¹		
Ford Meter Box Co., Inc.	Model B41	0 ¹		
Ford Meter Box Co., Inc.	Model B43	0 ¹		
Ford Meter Box Co., Inc.	Model B44	0 ¹		
Ford Meter Box Co., Inc.	Model BF13	0 ¹		
Ford Meter Box Co., Inc.	Model BF43	0 ¹		
James Jones Co.	Catalog J, Model 215	0 ¹		
¹ Stainless Steel only				
E. Water Meter Union Couplings				
Materials identified in the Water System Standards Section 402 Approved Materials List are approved for uses indicated at right.			0	0
Hays	5680 NM	0 ¹		
A.Y. McDonald Mfg. Co.	Model 4629	0 ¹		
Neptune Water Meter Union Couplings		0 ¹		
¹ Stainless Steel only				
F. Polyethylene Pipe				
Materials identified in the Water System Standards Section 402 Approved Materials List are approved for uses as indicated to the right, with the following additional requirements:				
Colored purple, Pantone 512 or equal.		0	0	0

DIVISION 600 – NON-POTABLE WATER SYSTEM STANDARDS APPROVED MATERIAL LIST

<u>DESCRIPTION</u>		<u>APPROVED FOR</u>		
<u>Manufacturer</u>	<u>Catalog or Model No.</u>	<u>RO</u>	<u>RI</u>	<u>BW</u>
Dupont	Polyethylene pipe copper tube size tubing, series 160, in 3/4-inch and 1-inch size only	0	0	0
Phillips	Driscopipe 5100 (Copper Tubing Size), polyethylene	0	0	0
Nipak	Xtra High Density Polyethylene Water Service Pipe (Copper Tube Size SDR9)	0	0	0
Lubrizol	Composite PVC Piping (FlowGuard)	0	0	0
G. HDPE Pipe AWWA C901				
Colored purple, Pantone 512 or equal.		0	0	0
1. JM Eagle		0	0	0
2. ISCO Industries		0	0	0
3. Chevron Philips Chemical Company LP, Performance Pipe		0	0	0
4. KWH Pipe, Sclairpipe		0	0	0
5. KWH Pipe, Weholite		0	0	0
H. Service Saddles				
Materials identified in the Water System Standards Section 402 Approved Materials List are approved for uses indicated at right.			0	0
James Jones	Catalog J, Model J979		0	0
A.Y. McDonald Mfg. Co.	3825 Bronze Double Strap, not applicable for use with PVC pipes		0	0
Romac Industries	Series 202 B, for use with PVC pipes only, and shall be bronze with double strap		0	0

DIVISION 600 – NON-POTABLE WATER SYSTEM STANDARDS APPROVED MATERIAL LIST

<u>DESCRIPTION</u>		<u>APPROVED FOR</u>		
<u>Manufacturer</u>	<u>Catalog or Model No.</u>	<u>RO</u>	<u>RI</u>	<u>BW</u>
I. Meter Boxes (shall conform with Standard Details)				
Materials identified in the Water System Standards Section 402 Approved Materials List are approved for uses as indicated to the right, with the following additional requirements:				
Colored purple, Pantone 512 or equal. Marked Recycled Water		0	0	
Colored purple, Pantone 512 or equal. Marked Non-potable Water				0
J. Valve Boxes (shall conform with Standard Details)				
Materials identified in the Water System Standards Section 402 Approved Materials List are approved for uses as indicated to the right, with the following additional requirements:				
Colored purple, Pantone 512 or equal. Marked Recycled Water		0	0	
Colored purple, Pantone 512 or equal. Marked Non-potable Water				0
K. Irrigation Meter Vaults (2-inches and larger)				
17 x 30-inch polymer meter box with 2-piece lid for 2-inch water services and blowoff assemblies. Colored purple (Pantone 512)			0	0
1. Armorcast A6001640PC-12 with A60001643DZ Cover and A600482 Read Lid			0	0

DIVISION 600 – NON-POTABLE WATER SYSTEM STANDARDS APPROVED MATERIAL LIST

<u>DESCRIPTION</u>		<u>APPLICABLE TO</u>		
<u>Manufacturer</u>	<u>Catalog or Model No.</u>	<u>RO</u>	<u>R-1</u>	<u>BW</u>
IV. PAINTS AND COATINGS				
Materials identified in the Water System Standards Section 402 Approved Materials List are approved for uses as indicated to the right, with the following additional requirements:				
Colored purple, Pantone 512 or equal.			0	
Fittings to be lined (interior) and coated (exterior) with epoxy coating Plascoat PPA 571 or equal and shall be purple, Pantone 512 or equal.		0		0
Carboline	Phenoline 341	0	0	0
Hydro-Pox	204 NSF	0	0	0
Induron	Protecto 401	0	0	0
Plascoat	PPA 571	0	0	0

DIVISION 600 – NON-POTABLE WATER SYSTEM STANDARDS APPROVED MATERIAL LIST

<u>DESCRIPTION</u>		<u>APPLICABLE TO</u>		
<u>Manufacturer</u>	<u>Catalog or Model No.</u>	<u>RO</u>	<u>R-1</u>	<u>BW</u>
V. MISCELLANEOUS				
A. Warning/Identification Materials				
1. 3-inch minimum width warning/identification (non-metallic) marking tape for buried pipelines, white or black printing on a purple field suggested color index 77742 violet #16, Pantone 512 or equal, continuous warning "CAUTION: NON-POTABLE WATER- DO NOT DRINK"		0	0	0
2. Tempo	Omni Marker, Model 168	0	0	0
B. Pressure Gages and Appurtenances				
Materials identified in the Water System Standards Section 402 Approved Materials List are approved for uses indicated at right.		0	0	0
C. Non-potable Water Use Advisory Sign				
1. Dimensions and identification per detail		0	0	0
D. Recycled Water Use Advisory Sign				
1. Dimensions and identification per detail		0	0	
E. Non-potable and Recycled Water Use Identification Decal				
1. Dimensions and identification per detail		0	0	0
F. Non-potable Water Use Identification Tag				
1. Dimensions and identification per detail		0	0	0
G. Recycled Water use Identification Tag				
1. Dimensions and identification per detail		0	0	

SECTION 608 – STANDARD DETAILS

608.01 STANDARD DETAILS

The standard details provided in Section 608 STANDARD DETAILS have been developed for the Non-potable water system. Standard details not presented in Section 608 STANDARD DETAILS should use the details presented in Section 403 STANDARD DETAILS of the latest edition of the *Water System Standards*, and all subsequent amendments and additions.

Trench Detail for Non-potable Water

Quick Coupling Valve for Non-potable Water

Advisory Sign for Non-potable Water

Advisory Decal for Non-potable Water

Advisory Tag for Non-potable Water

Point of Connection Sequence

Double Check Valve Assembly for Non-potable Water

Type X Meter Box Cover for Non-potable Water

Type X Valve Box Cover for Non-potable Water

Reinforced Concrete Jacket for Non-Potable Water (PVC Pipe)

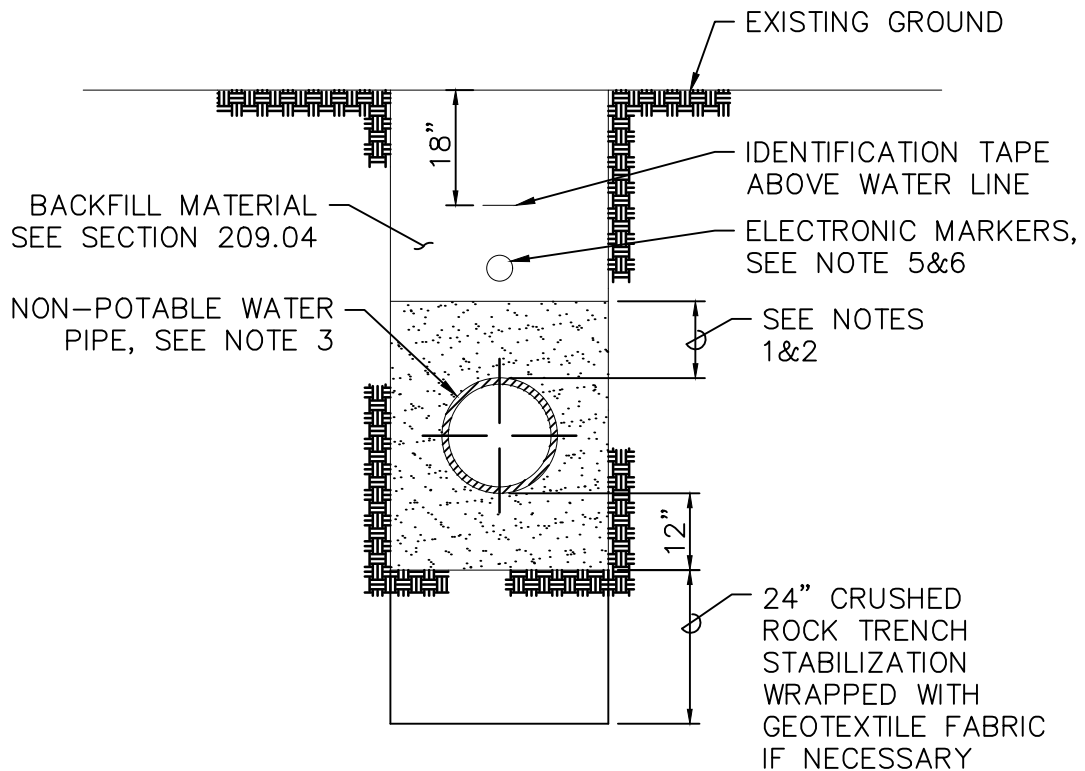

NOTES:

1. 12" OF CUSHION MATERIAL FOR PIPES 16" OR LARGER. 6" CUSHION MATERIAL FOR PIPES 12" OR SMALLER AT LOCATIONS WHERE INVERT IS ABOVE 4-FOOT ELEVATION.
2. 12" OF CUSHION MATERIAL FOR ALL PIPE SIZES AT LOCATIONS WHERE THE INVERT IS AT OR BELOW THE 4-FOOT ELEVATION.
3. NON-POTABLE WATER PIPE SHALL BE PURPLE COLOR CODED INTEGRALLY STAMPED OR MARKED AS "CAUTION-NON-POTABLE WATER-DO NOT DRINK" OR USE A PURPLE POLYETHYLENE OR VINYL WRAP OR USE NON-POTABLE WATER WARNING TAPE.
4. THE TERM "RECLAIMED WATER" IS THE SAME AS THE TERM "NON-POTABLE WATER".
5. INSTALL ELECTRONIC MARKERS OVER CENTER LINE OF PIPE AT A MINIMUM DEPTH OF 2 FEET AND A MAXIMUM DEPTH OF 3 FEET FROM FINISH GRADE.
6. INSTALL ELECTRONIC MARKER AT A MINIMUM CLEARANCE OF 6-INCHES ABOVE THE PIPE OR CONCRETE JACKET.

2022
REVISION

TRENCH DETAIL
 FOR NON-POTABLE WATER
 SCALE: NTS

STANDARD
 DETAILS

NP1

- LEGEND:
1. FINISHED GRADE
 2. PURPLE VALVE BOX
 3. STRUCTURAL HARDSCAPE WHERE OCCURS
 4. QUICK COUPLING VALVE WITH LOCKING PURPLE COVER AND ACME THREAD BRASS NIPPLE
 5. BRICK (1 OF 3)
 6. 3/4" WASHED CRUSHED AGGREGATE BASE
 7. BRASS NIPPLE
 8. BRASS 90 STREET ELL FITTING
 9. PRESSURE SUPPLY LINE
 10. BRASS 90 STREET ELL
 11. BRASS 90 ELL
 12. #4 REBAR STAKE (24" MIN)
 13. STAINLESS STEEL SCREW CLAMP
 14. PER BWS REQUIREMENTS

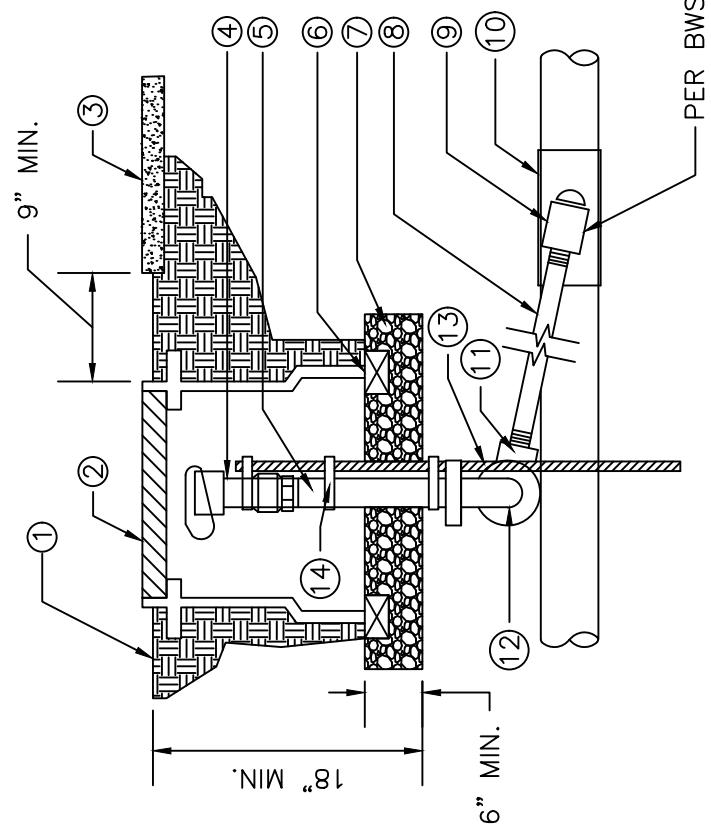

NOTE:
 1. QUICK COUPLERS SHALL BE OF A TYPE APPROVED FOR NON-POTABLE WATER USE.

QUICK COUPLING VALVE
 FOR NON-POTABLE WATER
 SCALE: NTS

STANDARD
 DETAILS

2022	
REVISION	
	NP2

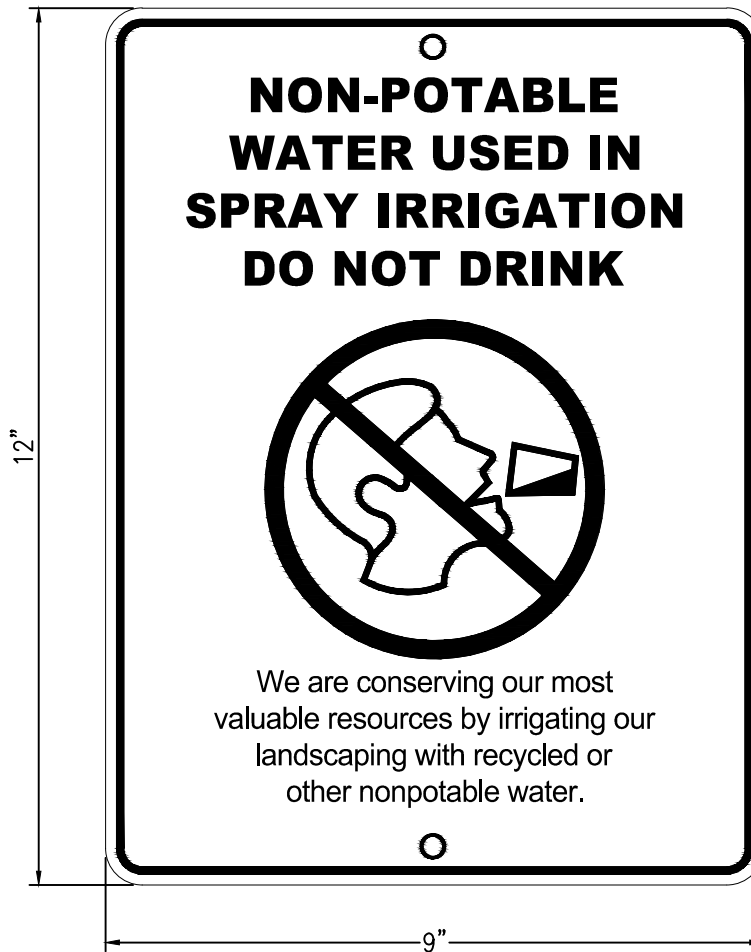

ADVISORY SIGN

SIZE: 12" HIGH X 9" WIDE

COLORS:

BACKGROUND; WHITE
 LETTERS; PANTONE 522 PURPLE
 CIRCLE/SLASH; DARK RED OVER WATER GLASS
 WATER GLASS; PANTONE 522 PURPLE
 ¼" WIDE BORDER; PANTONE 522 PURPLE

HOLES: 1/8"

2022
REVISION

ADVISORY SIGN
 FOR NON-POTABLE WATER
 SCALE: NTS

STANDARD
 DETAILS

NP3

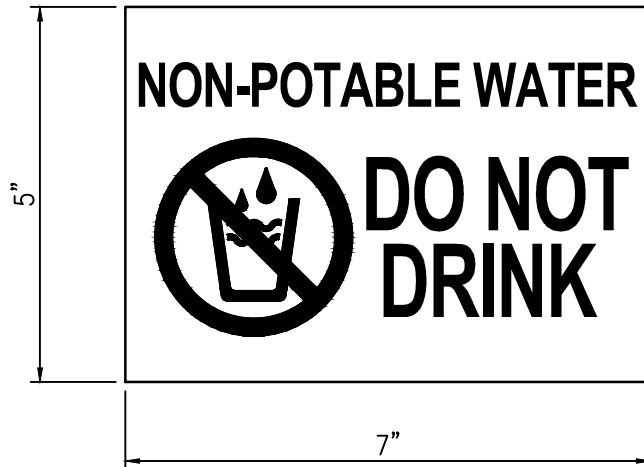

ADVISORY DECAL

SIZE: 5" HIGH X 7" WIDE

COLORS:
 BACKGROUND; WHITE
 LETTERS; PANTONE 522 PURPLE
 CIRCLE/SLASH; DARK RED OVER WATER GLASS
 WATER GLASS; PANTONE 522 PURPLE
 ¼" WIDE BORDER; PANTONE 522 PURPLE

2022
REVISION

ADVISORY DECAL
 FOR NON-POTABLE WATER
 SCALE: NTS

STANDARD
 DETAILS

NP4

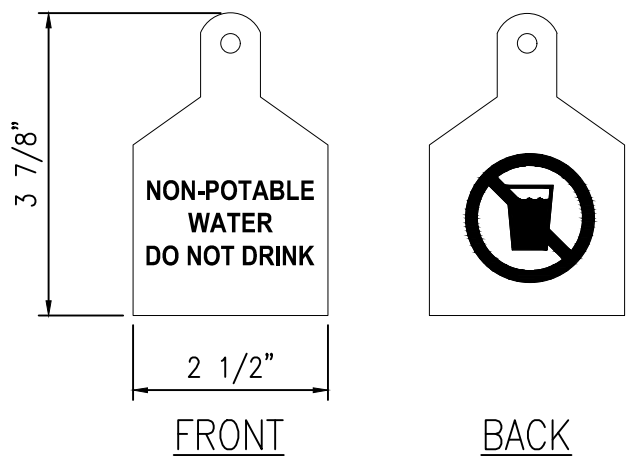

SAMPLE WARNING TAG. BACKGROUND PURPLE (PANTONE 512)
WITH BLACK LETTERING

2022
REVISION

ADVISORY TAG
FOR NON-POTABLE WATER
SCALE: NTS

STANDARD
DETAILS

NP5

POINT OF CONNECTION SEQUENCE
FOR NON-POTABLE WATER
SCALE: NTS

STANDARD
DETAILS

NP6

REVISION

2022

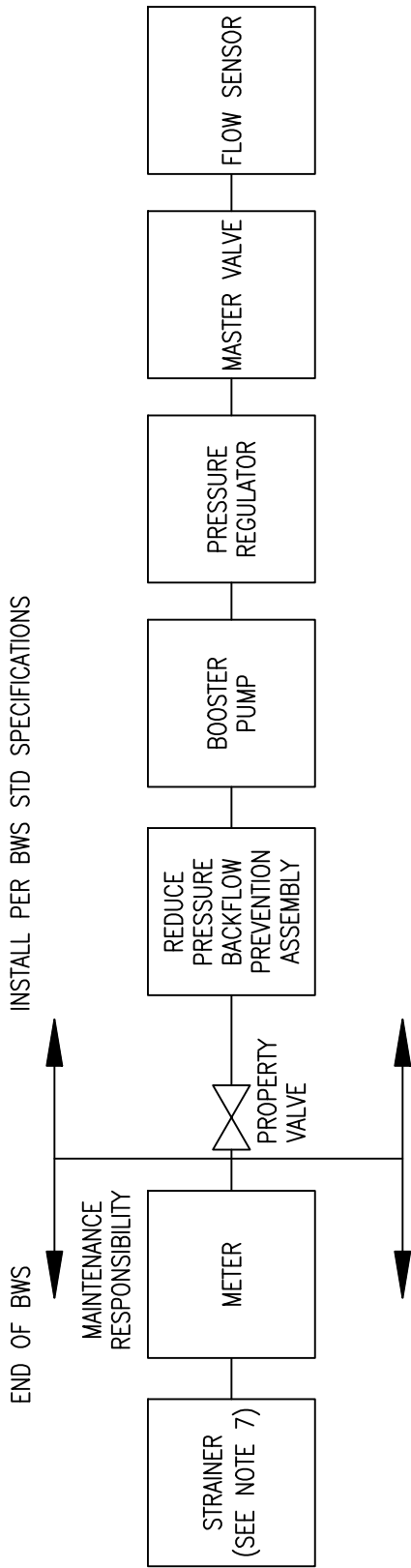

NOTES:

1. STRAINER SHALL BE AT LEAST THE SAME NOMINAL SIZE AS THE METER SIZE.
2. BACKFLOW PREVENTER SHALL BE THE SAME NOMINAL SIZE AS THE METER SIZE.
3. BACKFLOW PREVENTER REQUIRED ON USER SITES USING A FERTIGATION SYSTEM OR AS REQUIRED BY BWS.
4. STRAINER AND BACKFLOW PREVENTER SHALL BE LOCATED ABOVE GROUND IN A PROTECTED ENCLOSURE.
5. BOOSTER PUMP IF REQUIRED NEEDS TO HAVE A LOW FLOW/PRESSURE SWITCH.
6. ALL ITEMS IN CONNECTION SEQUENCE ARE NOT REQUIRED IN EVERY INSTANCE, BUT ITEMS USED SHOULD BE IN THE SEQUENCE AS DESCRIBED.
7. STRAINER TO BE INSTALLED AS DIRECTED BY THE MANAGER.

NONPOTABLE WATER POINT OF CONNECTION SEQUENCE

SIZE (INCHES)	H (INCHES)
3/4 TO 1-1/2	18
2 TO 3	24
4 TO 6	30
8 TO 10	36

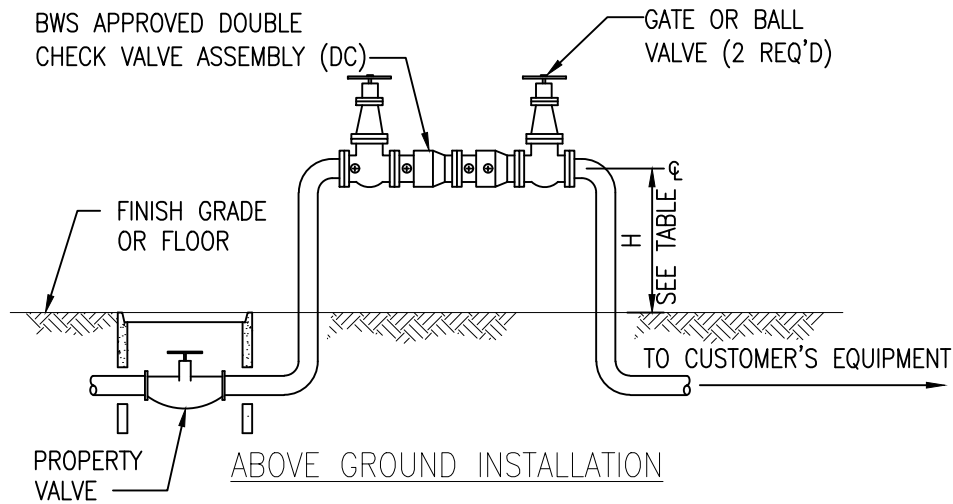

NOTES:

1. ANY CONNECTIONS OR TEES BETWEEN METER AND THE BWS APPROVED DOUBLE CHECK VALVE BACKFLOW PREVENTION ASSEMBLY (DC) MUST HAVE WRITTEN APPROVAL BY THE MANAGER & CHIEF ENGINEER.
2. THE DC SHALL BE INSTALLED WHENEVER THE MANAGER & CHIEF ENGINEER DEEMS IT NECESSARY TO PREVENT POTENTIAL CONTAMINATION TO THE PUBLIC WATER SYSTEM.
3. AT NO TIME SHALL THE BOTTOM OF THE DC BE LESS THAN 12" ABOVE GROUND, FLOOR, OR FLOOD LEVEL NOR MORE THAN 48" ABOVE AFOREMENTIONED GRADES.
4. THE DC SHALL BE INSTALLED AFTER THE WATER METER PRIOR TO ANY TEES AND BRANCHES.
5. WHENEVER THE DC IS LOCATED 5' OR MORE FROM THE WATER METER, A CONCRETE JACKET BETWEEN WATER METER AND BACKFLOW PREVENTION ASSEMBLY WILL BE REQUIRED TO AVOID A POTENTIAL CROSS CONNECTION.
6. THE DC SHALL BE INSTALLED PRIOR TO ISSUANCE OF THE WATER METER OR THE ACTIVATION OF WATER SERVICE.
7. REFER TO DIVISION 600, SECTION 604.04 FOR ADDITIONAL REQUIREMENTS AND TYPE OF BACKFLOW PREVENTER NEEDED.

2022
REVISION

**DOUBLE CHECK VALVE ASSEMBLY
FOR NON-POTABLE WATER**

SCALE: NTS

STANDARD
DETAILS

NP7

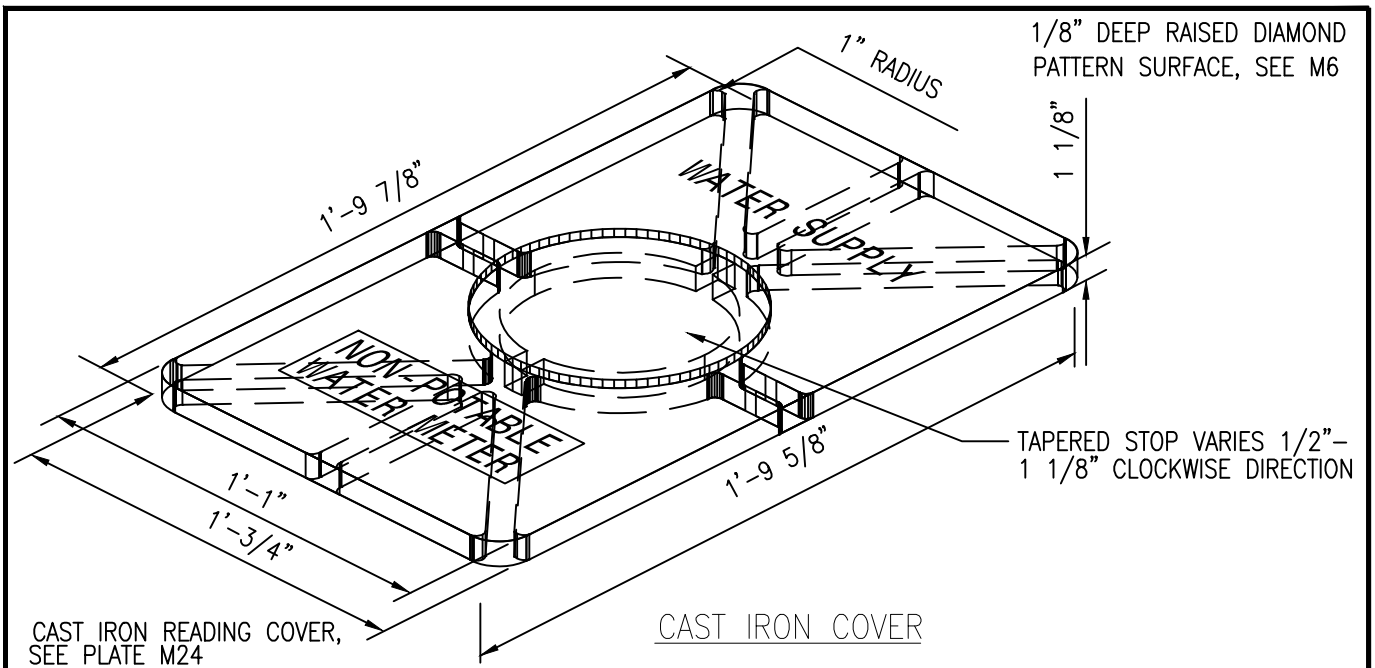

NOTES:

1. THICKNESS DIMENSIONS ARE NET. ADD 1/8" FOR RAISED SURFACE. USE 3/4" HIGH LETTERS
2. TYPE "X" METER BOX FOR 5/8", 3/4", & 1" METERS.
3. FIBER REINFORCED CONCRETE IS ALLOWED.
4. SEE PLATE M24 FOR READING HOLE COVER DETAIL.
5. INSTALL 6" WIDE x 4" THICK CONC COLLAR WITH WIRE MESH IN NON-CONCRETE/SIDEWALK AREAS WHERE APPLICABLE.

2022
REVISION

TYPE X METER BOX COVER
 FOR NON-POTABLE WATER
 SCALE: NTS

STANDARD
 DETAILS

NP8

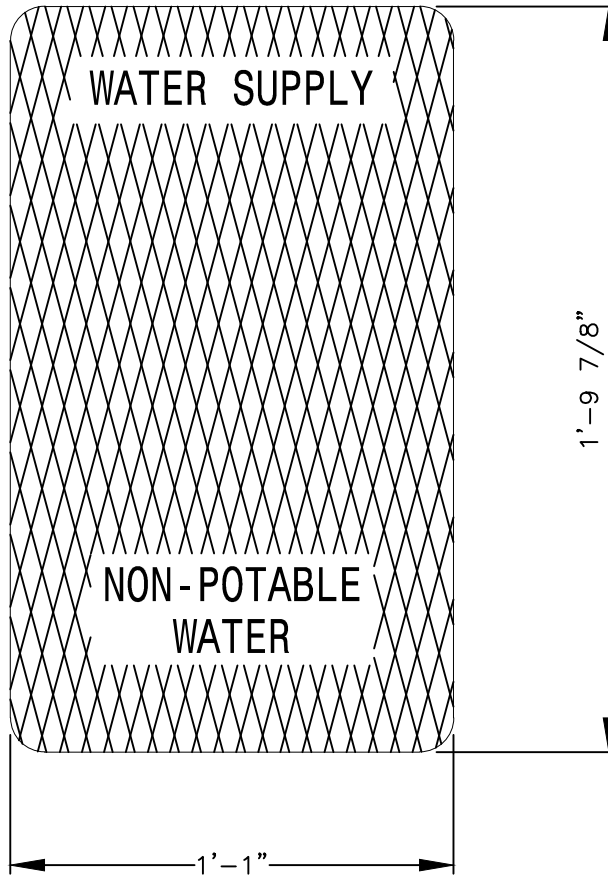

NOTES:

1. 1/8" DEEP RAISED DIAMOND PATTERN SURFACE. FOR CHECKERED PATTERN, SEE M3.
2. USE 3/4" HIGH LETTERS

2022
REVISION

TYPE X VALVE BOX COVER
 FOR NON-POTABLE WATER
 SCALE: NTS

STANDARD
 DETAILS

NP9

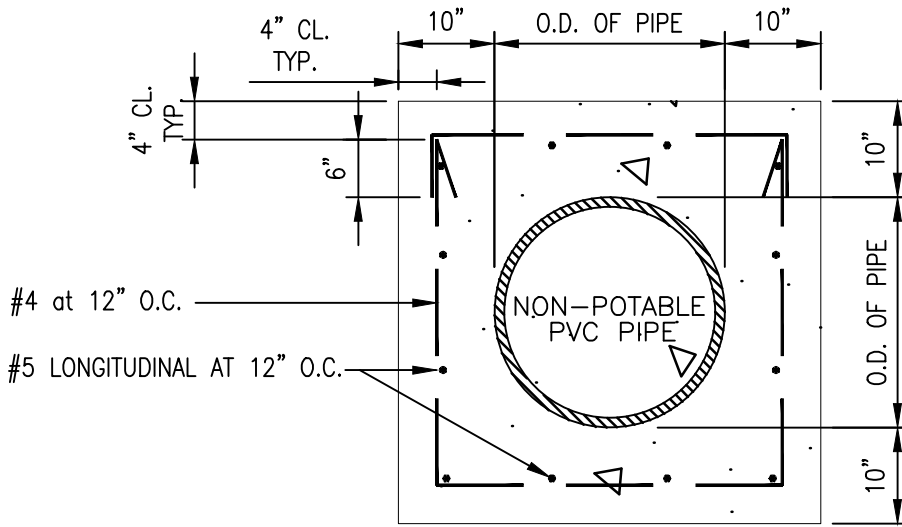

SECTION A-A

NOTE:

1. WHEREVER CONSTRUCTION JOINTS ARE REQUIRED, DWS APPROVED 6" RUBBER OR NEOPRENE WATERSTOPS OR CONCRETE BONDING AGENT APPROVED BY THE MANAGER SHALL BE INSTALLED.
2. CONCRETE SHALL BE DWS 2500 EXCEPT UNDER RESERVOIR FLOOR SLABS WHERE IT SHALL BE DWS 3500.
3. REINFORCING DESIGN APPLICABLE FOR STRAIGHT PIPE JACKETED SEGMENT. FOR SIPHON OR OFFSET, SUBMIT SHOP DRAWINGS.
4. PRECAST JACKETED WATERLINE SEGMENT SHALL BE DESIGNED AND STAMPED BY A LICENSED STRUCTURAL ENGINEER AND APPROVED BY MANAGER.

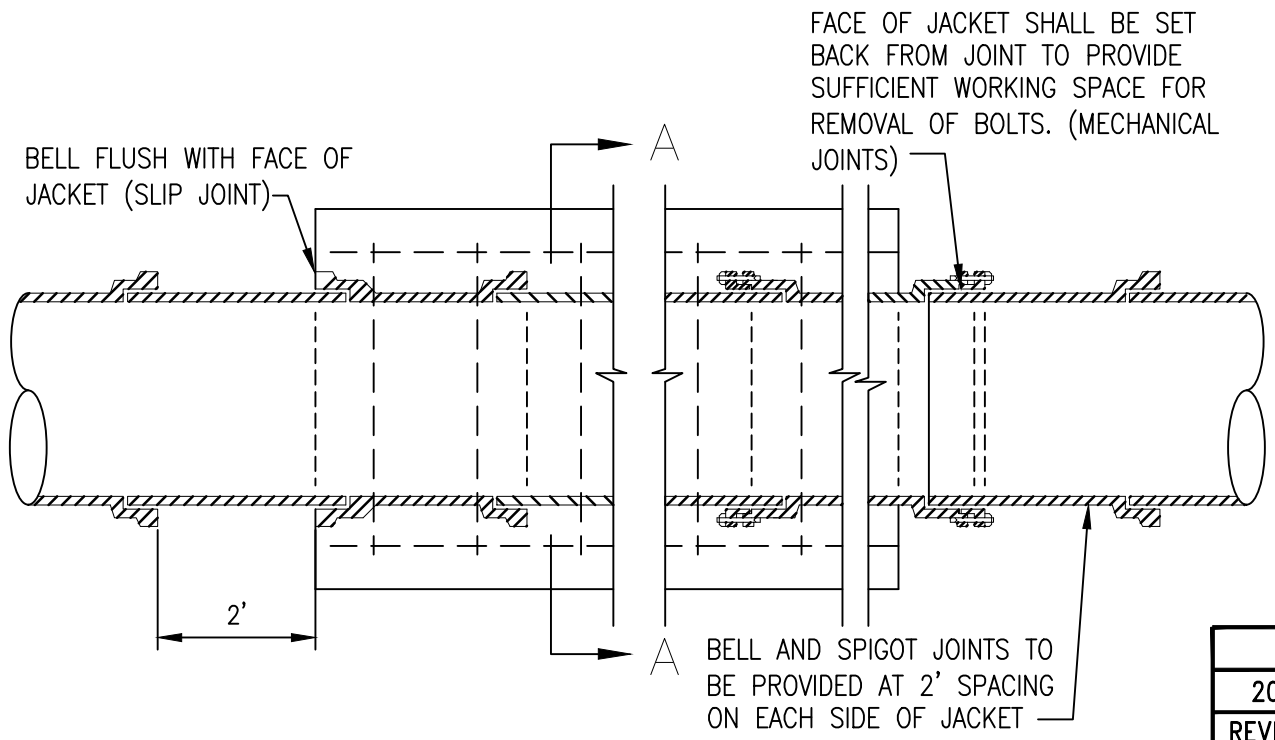

2022
REVISION

**REINFORCED CONCRETE JACKET
FOR NON-POTABLE WATER (PVC PIPE)**
SCALE: NTS

STANDARD
DETAILS

NP10